



BLE - FRN - ITP - _____
A

Order Example: BLE - FRN - ITP - 985

A - METAL FINISHES

POWDER COAT FINISHES:

- 100** Black
- 105** Textured Black
- 200** White
- 300** Dark Green
- 307** Emerald Green
- 311** Jadite
- 370** Mint
- 380** Chartreuse
- 390** Teal
- 400** Barn Red
- 420** Orange
- 470** Watermelon
- 480** Blush Pink
- 490** Magenta
- 500** Buttery Yellow

A - METAL FINISHES (CONTINUED)

POWDER COAT FINISHES:

- 570** Sunflower
- 600** Bronze
- 601** Chocolate
- 615** Oil-Rubbed Bronze
- 700** Royal Blue
- 705** Navy
- 710** Cobalt Blue
- 715** Delphite Blue
- 800** Industrial Grey
- 805** Charcoal Granite
- 810** Graphite
- 915** Silver Vein
- 920** Copper Vein
- 985** Galvanized with Clear Coat

IMPORTANT: (1) The Industrial Toilet Paper Holder has an estimated 2-4 week manufacturing time (2) There are no returns accepted on this product

DIMENSIONAL DRAWINGS

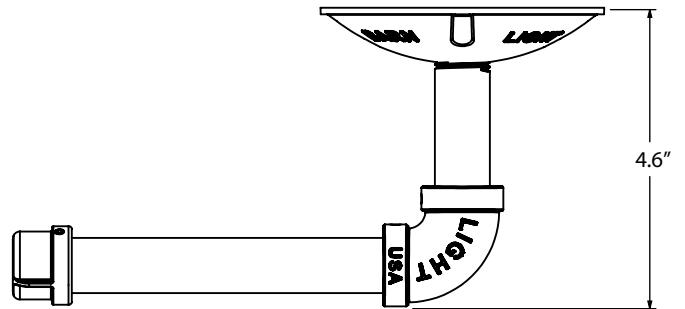
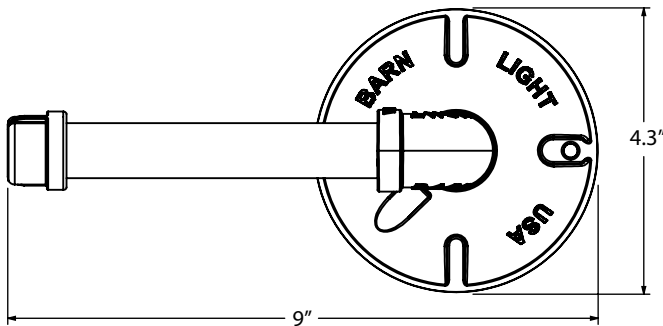

TOP VIEW

SPECIFICATIONS

CERTIFICATIONS & WARRANTY

MADE IN THE USA
 Manufactured and Hand-Crafted in Our 60,000 Square Foot Facility
 Located in Titusville, FL

MADE TO ORDER
 All Furniture Specially Made According to a Customer's
 Specifications and No Two Pieces Are Alike

LIMITED WARRANTY
 For Additional Information on Our Limited Warranty, Please See
 Our Terms & Conditions

DESIGN & FINISHES

CONSTRUCTION
 Lightweight Design, Constructed from 1/2" Aluminum Pipe
 Complete with One Backing Plate. Color Coordinated Mounting
 Hardware Included.

POWDER COAT FINISHES
 Polyester Powder Coat Finishes Are Electro-Statically Applied and
 Thermocured